

THE BEST WAY TO SAY PACKAGING



Giotto SERIES

High speed wrap-around cartoning machines

Made in Italy



- ▶ **Giotto**
- ▶ **Giotto 90P**
- ▶ **Giotto 90M**
- ▶ **Giotto Medium**
- ▶ **Giotto S**
- ▶ **Giotto SHC**
- ▶ **Giotto L Cont SHC**

POWERED BY

ATLANTA
NETWORK

Atlanta[®]
PACKAGING TECHNOLOGY & MACHINERY



The versatile and fast wrap-around cartoning machine

Giotto Series

The **Giotto Series** is the range of **wrap-around packaging machines** for the end of line by **Atlanta** with speed up to 50 cartons per minute.

The in-line feeding, with axial or 90° infeed, works continuously with linear movements of the product; the precision of the product moving unit ensures the high performance of the **Giotto Series** with all types of small or irregularly shaped containers, such as dispensers or bricks with straws.

The **cartoning machines** of the **Giotto Series** were designed with a modular structure to allow a broad range of customization to package the most varied products, even with very small dimensions.

The blank feeding with suction cups has many benefits, including managing **blanks of different thickness** even very thin (2 mm) or **blanks that are not perfectly flat**, the possibility to load blanks of different dimensions in the magazine to manage several formats more easily, gently moving even costly blanks or with graphics.

... The machine

- ▶ Frame and parts in contact with the product: **made of stainless steel** upon request.
- ▶ Each moving part is protected to ensure the **safety of line operators**.
- ▶ Sliding safety guards allow the operator to have full view of the machine, the wide opening ensures **easy access during maintenance** and cleaning.
- ▶ Machine designed to operate over three shifts, with **low energy consumption and silently**.
- ▶ **Touch screen panel** with simple and intuitive interface: this allows the operator to quickly set all parameters with a broad range of pre-sets.
- ▶ **Quick format changeover** pre-set that can be activated from the standard touch screen control panel; it does not require replacing parts.
- ▶ Optional **automatic format changeover**.
- ▶ **Combined blank** and product **detection** with sensors and photocells.
- ▶ Available in versions with **in-line feeding or at 90°**.



Atlanta. The best way to say packaging.



... The benefits of the Giotto Series

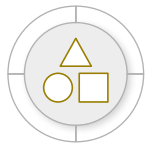

Suitable for the most varied formats: particularly suitable for irregularly shaped containers and bottles, with special caps or with dispenser.

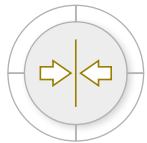

Thin blanks: blanks down to 2 mm thickness can be used.

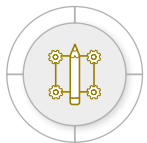

Designed for your product: the entire product path and its movement are optimised according to the samples you supply.



Inserter device: allows inserting a blank between the individual products to avoid them rubbing against each other while the package is transported.



Manuals and technical documentation: available in the language of the country of installation (upon request).
Certifications: meeting the regulations of the target country.



Smart integration: compatible with the most widespread enterprise management (ERP) and software protocols.

... Atlanta workflow

► **Analysis of the customer's needs:** acquisition of product and production line data, assessment of required performance, identification of machine model.

► **Engineering:** definition of technical characteristics and any required customization.

► **Production:** the machine is assembled by specialised technicians according to an assembly protocol that ensures continuous control of quality standards.

► **FAT (Factory Acceptance Test):** operating test with products and materials supplied by the customer, issue of the acceptance document.

► **Training:** the Atlanta tutors are technicians trained to transfer all required expertise to your line operators so they can perform routine maintenance independently.

► **Installation:** the machine is commissioned and tested by Atlanta technicians to ensure utmost efficiency and to train the operators.

... Aftersales service

► **Scheduled maintenance:** preventative maintenance can be scheduled to optimise and minimise line downtime.

► **Remote assistance:** this service is available in various languages and allows providing immediate support to your technicians in the event of an emergency.

► **Remote support:** when this service is activated, our technicians can operate directly on the machine software, decreasing waiting time and costs.

► **On-site assistance:** this service is provided by a team of multi-language travelling technicians with mechanical and software expertise.

► **Spare parts:** storing and supplying service for original spare parts to maintain maximum efficiency of your machine.



For an environmentally friendly and resistant package

Giotto Series

... Designed to be versatile

The pneumatic product movement unit, **on single or multiple rows**, precisely places **small or large** products, complex-shape packages, fragile packages or packages with an irregular support base, always creating precise and compact packages.

This machine for the end of line is characterised by the ease it allows to switch

from one format to the next for the product to be packaged, selecting the pre-set formats on the touch screen display without making any mechanical change.

The interface is available in multiple languages and guides the user through each operation with **simple and intuitive** instructions, to minimise the possibility of human error.

CASE HISTORY

Giotto: 2 mm blank with graphic and handle. The design of this package required a cartoning machine that is extremely precise when folding and capable of using a single-coated blank of only 2mm of thickness.



SOME EXAMPLES OF THE MOST USED FORMATS

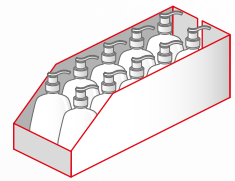
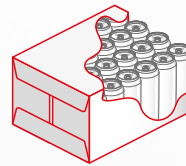
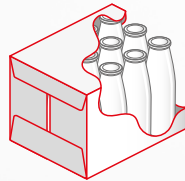
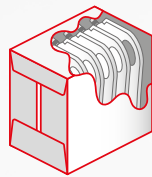
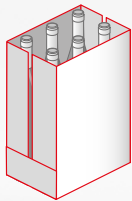

CASE HISTORY

Giotto 90M: quick format changeover even with different products. The customer needed a cartoning machine to manage different formats, capable of creating packages with a variable number of units.



Atlanta. The best way to say packaging.



Operating diagram

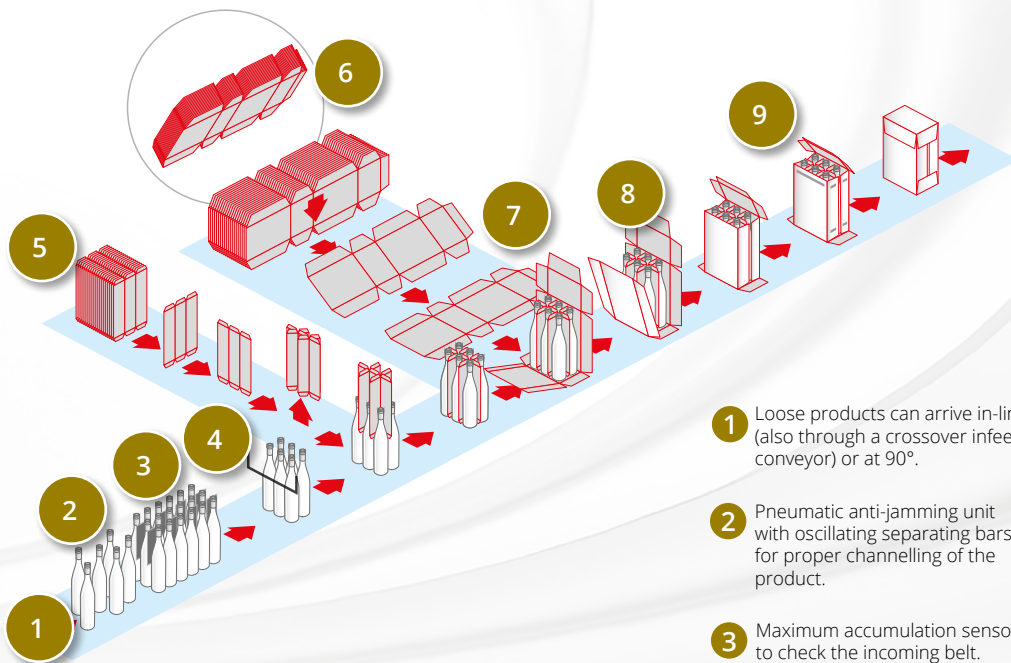

- 1 Loose products can arrive in-line (also through a crossover infeed conveyor) or at 90°.
- 2 Pneumatic anti-jamming unit with oscillating separating bars for proper channelling of the product.
- 3 Maximum accumulation sensor to check the incoming belt. Minimum accumulation sensor for each channel.
- 4 Alternated separation without mechanical gears or continuous separation.
- 5 Optional: inserter device unit
- 6 Magazine available in vertical or horizontal version, according to the models. The blank is taken from the magazine by a suction cup system.
- 7 The first fold prepares the blank to receive the group of products.
- 8 The box is formed around the product with consecutive folds, while passing along the production line.
- 9 Glued points are applied and the flap can be internal (standard) or external (optional).

CASE HISTORY

Giotto SHC: for customized packages. The customer needed to position pyramid-shape bottles according to a specific orientation and an inserter blank to protect the bottles. Adding more control sensors ensured that each single box sent to the palletizer was properly composed.



Giotto Series

Model	Giotto	90P	90M	Medium	S	SHC	L Cont SHC
PACKAGING							
Tray	✓	✓	✓	✓	✓	✓	✓
Wrap-around	✓	✓	✓	✓	✓	✓	✓
DIMENSIONS							
Length (mm)	7,765	6,575	6,575	7,765	7,765	8,300	12,850
Width (mm)	2,345	5,380	5,380	3,000	3,000	3,950	3,950
Height (mm)	2,200	2,200	2,200	2,200	2,200	2,200	2,200
SPEED packages/minute							
Single lane	25	20	25	35	40	45	50
FEEDING							
In-line (4 channels)	✓			✓	✓	✓	✓
90°	optional	✓	✓	optional	optional	optional	
Anti-jamming unit	✓ (only in-line)					✓ (only in-line)	
SEPARATION							
Pusher		pneumatic	mechanical				
Long crossbars	✓			✓	✓	✓	
Continuous							✓
MAGAZINE							
Capacity	300	300	300	250	250	300	300
Possibility of extension	500	500	500			600	600

SPECIFICATION

Blank thickness	2 to 5 mm
Upper flap closure	internal
Installed power	25 kW
Voltage	400V - 3-Phase/50Hz + N + G
Electrical protection	IP54
Compressed air consumption	4 NI/cycle at 6 bar
Operating temperature	min +5°C - max +40°C
Relative humidity	max 70%
Total weight	4,000 kg
Product presence check	feelers + photocells
Machine colour	■ RAL 7037

OPTIONAL

Automatic format changeover
Additional channels
Inserter device unit
Magazine extension
1/4 pallet tray
Adjustable feeding guides with handwheels
Manual or automatic centralized lubrication
Motorized crossover infeed conveyor
Photocells for product presence check after separation phase
External upper flap closure
Partial stainless steel version
Customized RAL colour
4.0 Industry
Electrical panel air conditioning
Teleservice - Remote support

Giotto L Cont SHC
Version with magazine extension

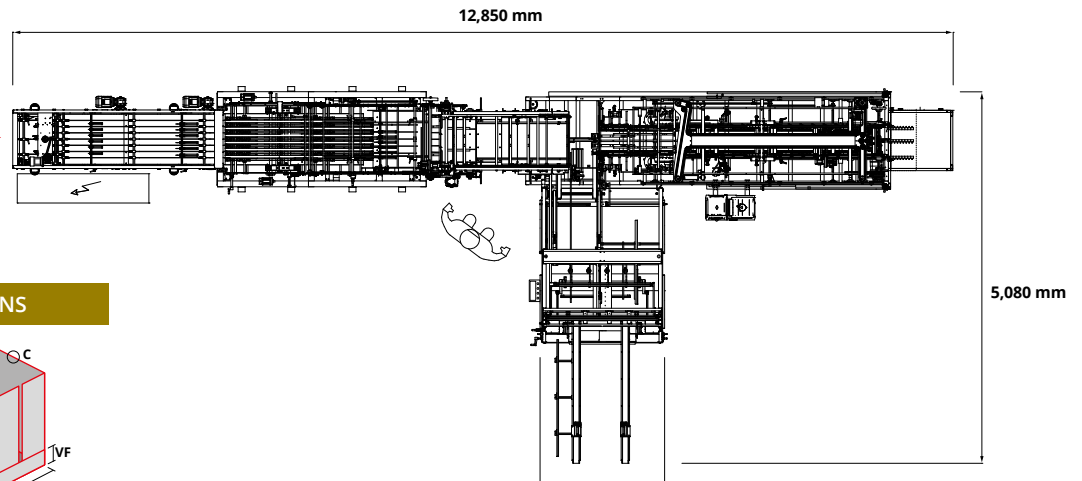

BLANK-TRAY DIMENSIONS

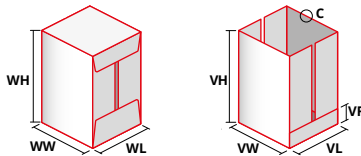

	Giotto - 90P - 90M Medium - S		Giotto SHC Giotto L Cont SHC	
	Minimum mm	Maximum mm	Minimum mm	Maximum mm
WW	170	550	250	450
WL	115	350	200	350
WH	120	350	120	350
VW	170	550	250	450
VL	120	350	200	350
VH	60	350	60	350
VF	50	350	50	350
C	2	5	2	5

Data to be confirmed upon reception of the sample.

MEASURES IN THE TABLES REFER TO STANDARD PRODUCTS. PRODUCTS OUTSIDE THIS RANGE CAN ALSO BE MANUFACTURED. Data to be confirmed upon reception of the sample.

Giotto SHC

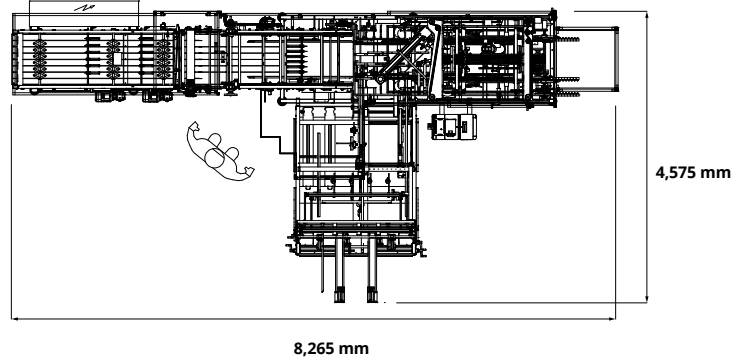

Giotto

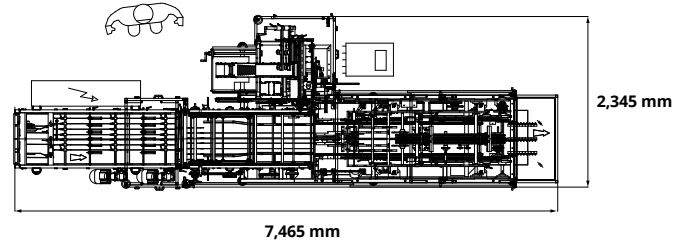

**Giotto Medium
Giotto S**

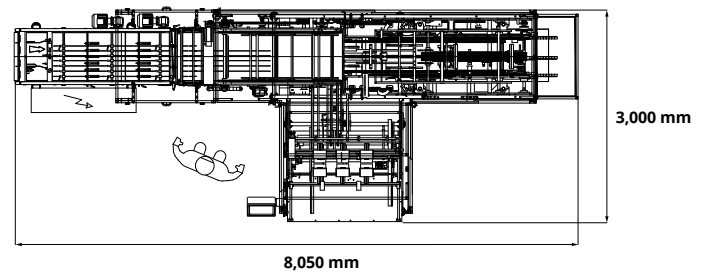

Giotto 90

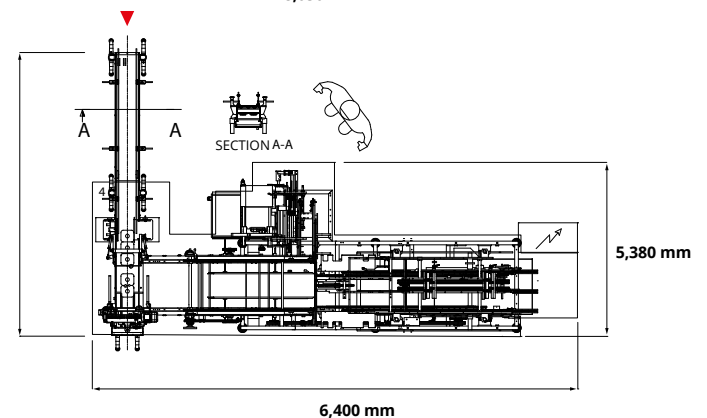

Atlanta reserves the right to change the design and/or specification of products without prior notice. Part of this information is general only: the customer must ensure they apply to their needs; some functions are optional; out of scale drawings are valid as a description only.



THE BEST WAY TO SAY PACKAGING

Atlanta[®]
PACKAGING TECHNOLOGY & MACHINERY

ATLANTA spa Via Europa, 13 - 40010 Sala Bolognese (BO) - Italy | Tel. +39 051 722792 | info@atlantapackaging.eu
Sales: sales@atlantapackaging.eu | Service: service@atlantapackaging.eu | Spare parts: spares@atlantapackaging.eu

www.atlantapackaging.eu